

CAD DRAWING - NO MANUAL REVISIONS

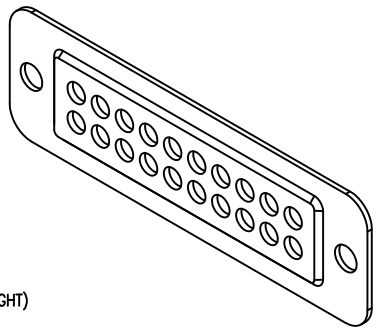
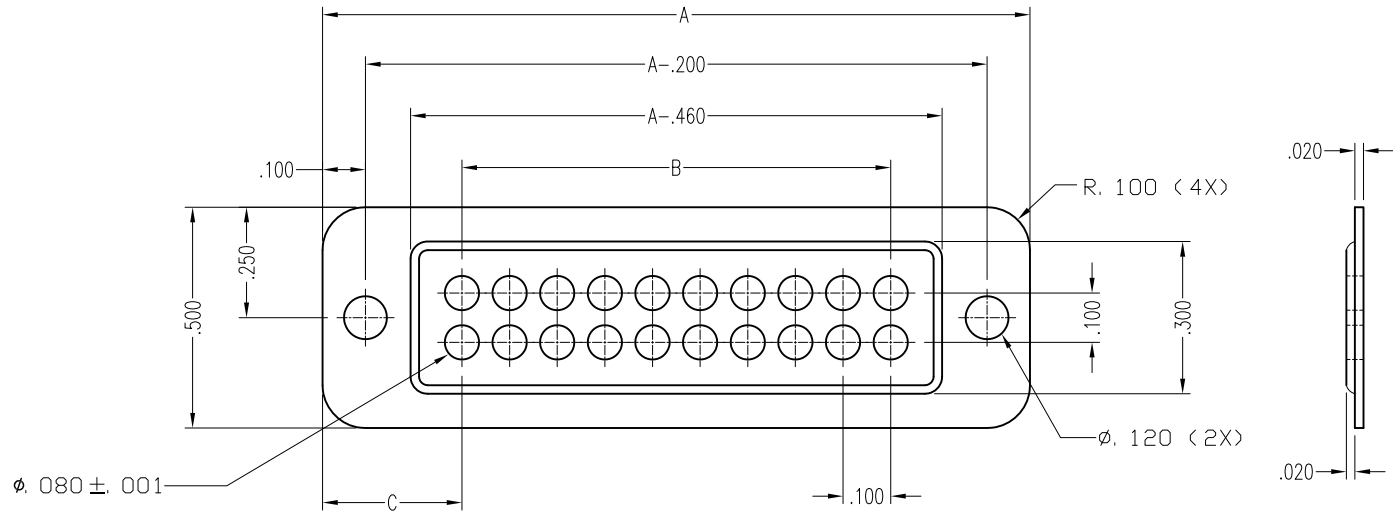

NOTES:

- 1) MATERIAL: BRASS, UNS NO. C26000/27000
- 2) PLATING: SILVER 200-400μ INCHES (SEMI-BRIGHT)
- 3) REMOVE ALL BURRS AND SHARP EDGES.
- 4) ALL DIMENSIONS ARE AFTER PLATING.
- 5) ALL MATERIALS AND FINISHES ARE ROHS COMPLIANT.
- 6) EVERY HOLE CAN BE THROUGH OR BLOCK FOR LATER PRODUCOR
- 7) TOLERANCE OF HOLES CAN'T BE CUMULATE

PART NO.	PLATE LENGTH(A)	NO.OF FILTERED LINES PER ROW	B	C
59005S005	*1.060	5	0.4	0.33
59005S006	*1.560	10	0.9	0.33
59005S007	2.560	20	1.9	0.33
59005S008	3.560	30	2.9	0.33

* FOR PLATE WIDTHS 1.060 AND 1.560 THERE WILL BE NO COINING



SHANGHAI PHOENIX COMMUNICATION & TECHNOLOGY COMPANY LTD.
SHANGHAI, CHINA.

UNLESS OTHERWISE SPECIFIED, PHOENIX WORKMANSHIP STANDARDS APPLY
TOLERANCES ON: DECIMALS: .XX ± .01 .XXX ± .003 ANGLES ±1/2°
DIMENSIONS IN INCH DO NOT SCALE PRINTS
UNLESS OTHERWISE SPECIFIED DIMENSIONS ARE IN INCH

DESCRIPTION	
PLATE FOR FILTER	
DRAWN: QUYANGLING	DWG NO. 59005S005/8
CHECKED: KGU	
APPROVED: SYANG	SHEET 1 OF 1

ZONE	REV	DESCRIPTION	MM/DD/YY
	01	PRELIMINARY	06/17/08