

CAD DRAWING - NO MANUAL REVISIONS

THESE ITEM(S)/TECHNICAL DATA ARE CONTROLLED FOR EXPORT FROM THE UNITED STATES IN ACCORDANCE WITH THE US EXPORT ADMINISTRATION REGULATIONS (EAR). DIVERSION CONTRARY TO U.S. LAW PROHIBITED.

Double Row

Single Row

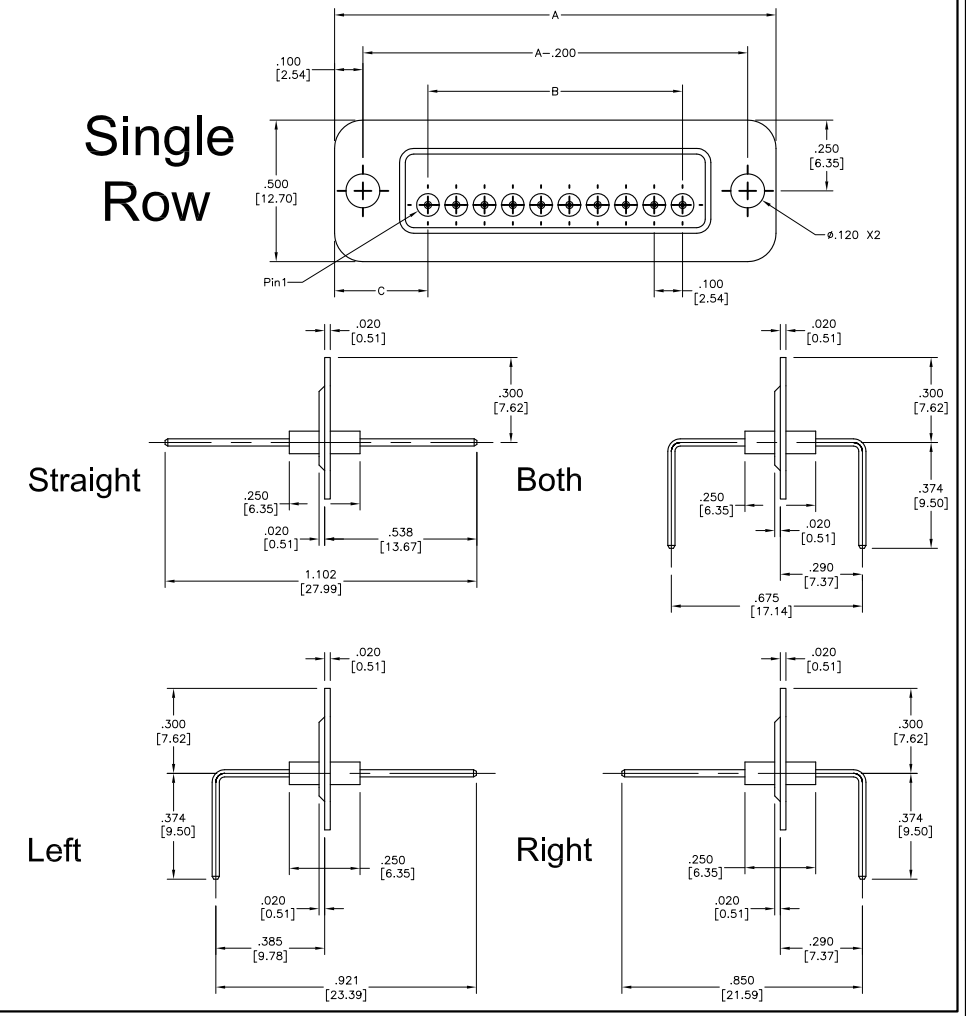
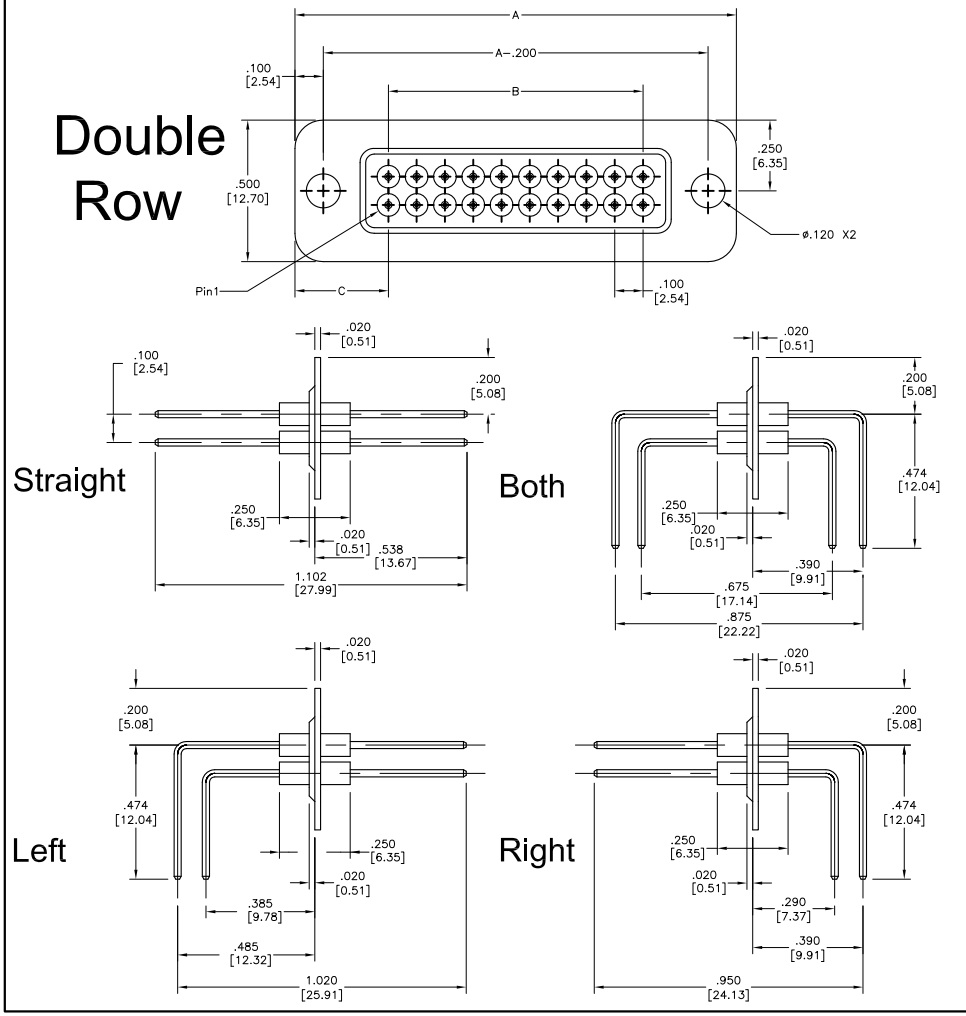

ZONE	REV	DESCRIPTION	MM/DD/YY
	01	PRELIMINARY	12/01/08



SHANGHAI PHOENIX COMMUNICATION & TECHNOLOGY COMPANY LTD.
SHANGHAI, CHINA.

UNLESS OTHERWISE SPECIFIED, PHOENIX WORKMANSHIP STANDARDS APPLY
TOLERANCES ON: DECIMALS: .XX 0.01 .XXX 0.003 ANGLES $\pm 1/2^\circ$ 32°
DIMENSIONS IN INCH (mm) DO NOT SCALE PRINTS
UNLESS OTHERWISE SPECIFIED DIMENSIONS ARE IN INCH

DESCRIPTION	
DRAWN: OUYANGLING	DWG NO.
CHECKED: JAMES	
APPROVED: SAMSON	SHEET 1 OF 2

8 7 6 5 4 3 2 1

CAD DRAWING - NO MANUAL REVISIONS

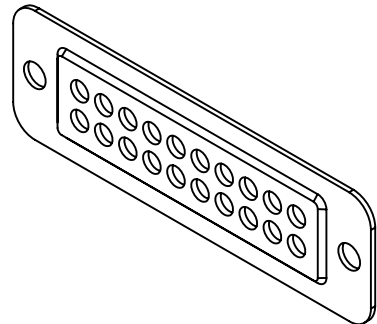
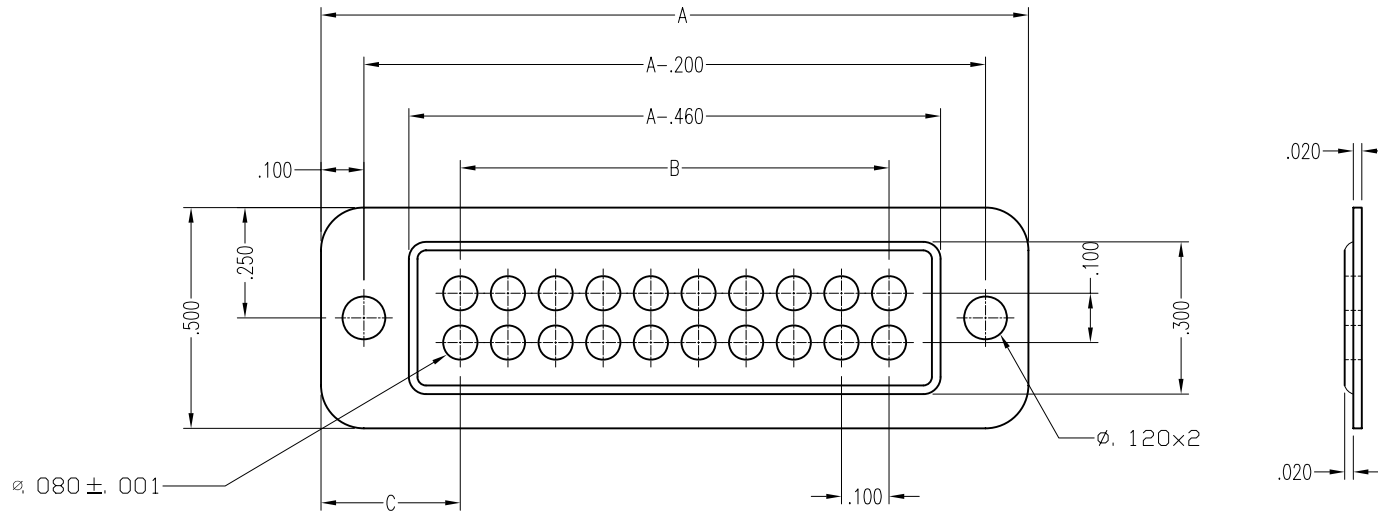

NOTES:

- 1) MATERIAL: BRASS, UNS NO. C26000/27000
- 2) PLATING: SILVER 200-400μ INCHES
- 3) REMOVE ALL BURRS AND SHARP EDGES.
- 4) ALL DIMENSIONS ARE AFTER PLATING.
- 5) ALL MATERIALS AND FINISHES ARE ROHS COMPLIANT.

PART NO.	PLATE LENGTH(A)	NO. OF FILTERED LINES PER ROW	B	C
59005S005	*1.060	5	0.4	0.33
59005S006	*1.560	10	0.9	0.33
59005S007	2.560	20	1.9	0.33
59005S008	3.560	30	2.9	0.33

* FOR PLATE WIDTHS 1.060 AND 1.560 THERE WILL BE NO COINING

A

ZONE	REV	DESCRIPTION	MM/DD/YY
	-	PRELIMINARY	06/17/08



SHANGHAI PHOENIX COMMUNICATION & TECHNOLOGY COMPANY LTD.
SHANGHAI, CHINA.

UNLESS OTHERWISE SPECIFIED, PHOENIX WORKMANSHIP STANDARDS APPLY

TOLERANCES ON: DECIMALS: .XX ± .01 .XXX ± .003 ANGLES ±1/2° 32'
DIMENSIONS IN INCH DO NOT SCALE PRINTS
UNLESS OTHERWISE SPECIFIED DIMENSIONS ARE IN INCH

DESCRIPTION		PLATE FOR FILTER	
DRAWN: DUYANGLING	DWG NO.	59005S005/8	
CHECKED: KGU			
APPROVED: SYANG		SHEET	1 OF 1

8 7 6 5 4 3 2 1